

- NOTES:
- ① APPLY LIGHT COAT OF BLUE GOOP TO MATING SURFACES.
  - ② TORQUE TO 35 FT-LBS (47 NM).
  - ③ AFTER CONNECTING HP WATER INLET, HAND TIGHTEN PC 3 (LOCK COLLAR).

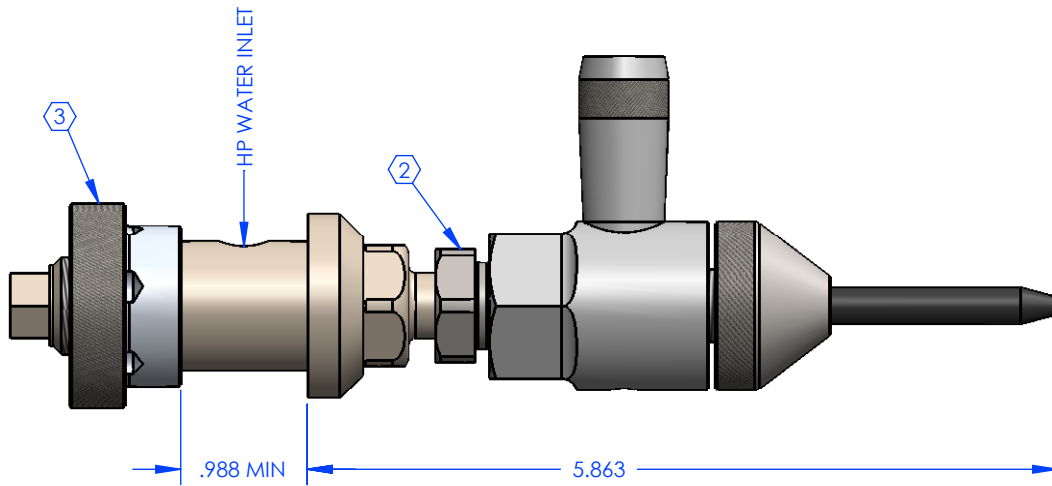

ITEM	QTY.	PART NUMBER	DESCRIPTION
1	1	100027-3-C	GLAND NUT, ADJ. NOZZLE BODY
2	1	100217-2	LOCK COLLAR, MAXJET 5 ADAPTER
5	1	100173-281-1	COALESCING PLENUM, IDE, SINGLE PORT, .281
6	1	100217-1-A	NOZZLE BODY, MAXJET 5 ADAPTER
7	1	100027-2-D	COLLAR, ADJUSTABLE NOZZLE BODY, P-III
8	1	100100-30-3	ABRASIVE NOZZLE, 3" LONG
9	1	100172-1	CLAMP NUT, IDE



PROPRIETARY AND CONFIDENTIAL:  
 THE INFORMATION CONTAINED IN THIS DRAWING IS THE SOLE PROPERTY  
 OF H2O JET INC. ANY REPRODUCTION IN PART OR AS A WHOLE WITHOUT  
 THE WRITTEN PERMISSION OF H2O JET INC. IS PROHIBITED.

DRAWN: M.H.

CHECKED: J.N.

APPRVD: H.A.

SCALE: 2:3

DATE: 01/08/08

TITLE:  
**NOZZLE BODY, ADJUSTABLE,  
 MAXJET 5 TO IDE ADAPTER**

SIZE **A** DWG. NO.  
**301200-1**

REF. NO:

MADE FROM:

REV. **0** SHEET **1 OF 1**

ECN #	Date	Rev	Reason for Changes	Drwn By	Chk By	Apvd By