

ITEM NO.	QTY.	PART NUMBER	DESCRIPTION
1	1	100221-1-B	ADAPTER, BODY, MAXJET 5 TO IDE (NON TILT-A-JET)
2	1	100221-2	ADAPTER, INSERT, MAXJET 5 TO IDE (NON TILT-A-JET)
3	1	301129-1-XX	IDE-II, ABRASIVE, SINGLE PORT, .XX", (.281" ID)

NOTES:

1. APPLY BLUE GOOP TO SURFACES (A).
2. TORQUE IDE-II TO 30-35 FT-LBS. DO NOT OVER TIGHTEN.
3. INSERT ITEM 2 INTO THE CENTER OF POCKET IN ITEM 1. MAKE SURE IT SEATS FLAT.
4. THREAD ASSEMBLY INTO CUSTOMERS MAXJET 5 NOZZLE BODY.
5. TORQUE TO 35 FT-LBS.

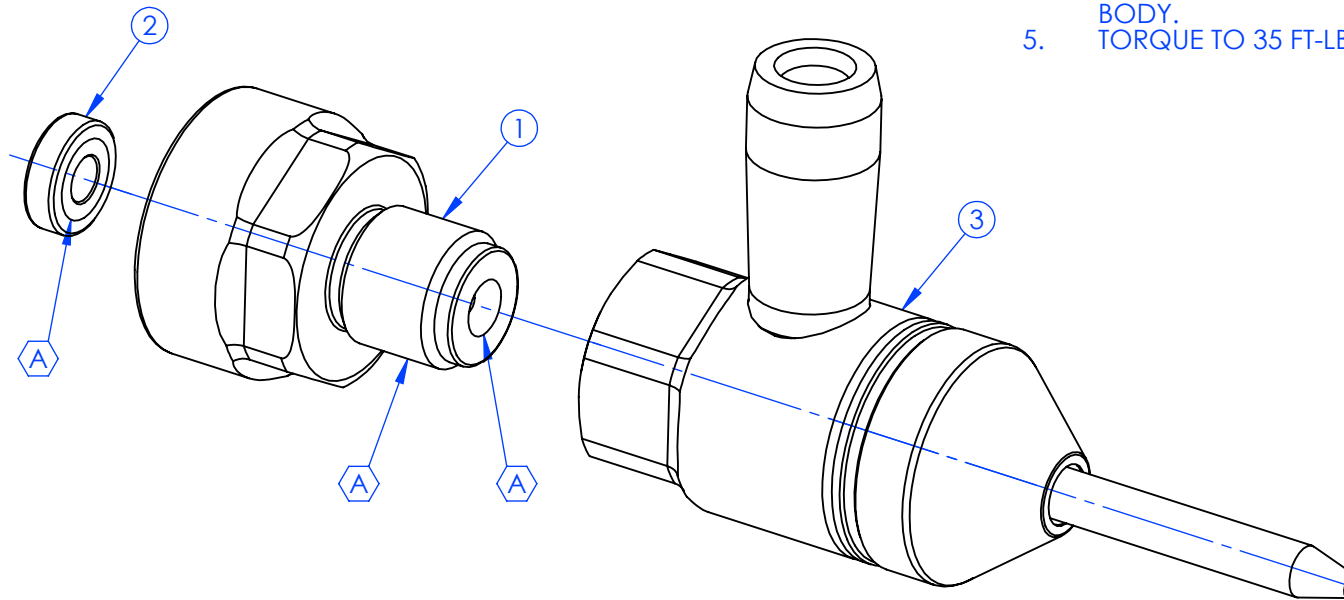

PROPRIETARY AND CONFIDENTIAL:
 THE INFORMATION CONTAINED IN THIS DRAWING IS THE SOLE PROPERTY OF H2O JET INC. ANY REPRODUCTION IN PART OR AS A WHOLE WITHOUT THE WRITTEN PERMISSION OF H2O JET INC. IS PROHIBITED.

DRAWN: M.H.	TITLE: ADAPTER, MAXJET 5 TO IDE (NON TILT-A-JET)	REF. NO: -	
CHECKED: H.A.		MADE FROM: -	
APPRVD: H.A.	SIZE A	DWG. NO. 301200-2	REV. 0
SCALE: NTS			SHEET 1 OF 1
DATE: 3/21/2011			